

**THE (A)DVANCED
ART OF CONTROL
NEXT GENERATION**

Neuffener Strasse 29
D-72636 Frickenhausen
Tel: (+49) 7025 - 911 007
Fax: (+49) 7025 - 911 008
Email: info@h-c-s-gmbh.de
www.h-c-s-gmbh.de



Universal Digital
Amplifier and Controller

**NEW UPGRADED
VERSION!**

DAC-4x(A)

**VERSIONS FOR OPEN AND CLOSED LOOP APPLICATIONS
FOR ALL KINDS OF VALVES W/O FEEDBACK SYSTEMS**

- ▶ **Amplifier for 1 or 2 proportional valves with or w/o feedback**
- ▶ **Fully digital P-PID-Controller for 1 or 2 closed loop systems**
- ▶ **Closed loop applications made easy: position, pressure, velocity, force, rpm, acceleration, temperature, etc.**
- ▶ **High performance 32 bit floating point CPU**
- ▶ **Superfast cycle time -->best dynamic behavior**
- ▶ **Supply voltage range nom. 12 - 24 V DC**
- ▶ **Operating temperature range - 40° C - + 70° C**
- ▶ **Multiple analog and digital I/O**
- ▶ **Analog inputs U/I selectable and with very high resolution (16 bit)**
- ▶ **Interface per choice: USB-C or RS232 (Sub-D 9 pole)**
- ▶ **Easy usage / operation by means of WINDOWS program **HcSTool** - now also with 4-channel oscilloscope**
- ▶ **Optional with certified PROFIBUS / PROFINET interface**
- ▶ **Optional with Ethernet-IP interface**



**PROFI[®]
BUS**

**PROFI[®]
NET**

EtherNet/IP

**1 BOARD WITH 11 DIFFERENT ARCHITECTURES (OPERATION MODES)
FOR AN UNLIMITED NUMBER OF APPLICATIONS - HYDRAULIC,
PNEUMATIC OR OTHER KIND OF AUTOMATION APPLICATIONS**

1 Applications and usage

Amplifier and controller boards series DAC-4x(A) are used for:

- Control of proportional valves of all kinds with and without electrical feedback: proportional directional valves, direct and pilot operated; flow control valves; pressure limiting and pressure reduction valves; cartridge- and servovalves
- Control of process values within hydraulic and other machines or systems: position, velocity, pressure, rpm, torque, force or load, temperature, etc.
- Flow and pressure control for pumps (load limiting function and feedback for spool position of control valve optional) on request
- Simultaneous control of two process values: e.g. P/Q-control and pump controller, control of two pressures, control of pilot and mainstage spool position, cascaded controllers, control of process values without usage of valves (subsequent electronics, e.g. F/U converters)

2 Features

- Fully digitized amplifier and controller
- All adjustments and parameter setting possible by means of keypad and display
- Flexible and reliable system; use of a modern high performance 32-bit floating-point CPU
- Software update possible via PC by means of USB-C or RS232 interface
- Flexibility due to possible hardware and software extensions and options for customer and application specific requirements (e.g. bus-interface, special output stages, etc.)
- Variable settings for all kinds of solenoid systems and sensor signals
- Change of selected parameters "on-the-fly" without interference or interruption of closed loop system; monitoring of display values and visualization of dynamic processes with 4-channel oscilloscope by means of **HCSTool**
- Very high resolution and accuracy for analogue set points and feedback signals due to a 16-bit A/D-converter
- D/A-converter with 2 analog outputs to perform controller functions and / or enable subsequent electronic devices and monitoring (0 ... ± 10 V or 0 (4) ... 20 mA, 12 bit resolution) also for ease of commissioning and trouble shooting (monitor signal for internal values)
- Several versions with and without keypad and different functions and options are available
- All kinds of customer specific adaptations of hardware and software for special applications are possible. Just ask us and we provide the right solution!
- LVDT interface (1 or 2 channel) for special feedback applications on request
- With interface for SSI sensor (up to 30 bit) available.
- Optional available with PROFIBUS, PROFINET or Ethernet-IP interface. Other bus interfaces on request
- Optional special versions for servo valves available

3 New generation „DAC-4x(A)“ replacing DAC-4

The predecessor board „DAC-4“ (more than 16,000 devices are being used world wide), which has been used very successfully to date, with all kinds of variants and versions, will be fully replaced by the new generation. Naming of the new generation remains the same, except for the suffix (A). The new version is thus called "DAC-4x(A)".

Key target points for introduction of the successor generation are:

- Provide a basically 100% function and pin-compatible successor
- Ensure availability for the next decade to come
- Extend general functionality
- Improve functionality for all analog inputs (command and feedback). SSI interface for digital encoder available.
- Boost performance to a significant higher level
- Advanced computational power due to usage of 32 bit floating point CPU
- Quadruple resolution for analog inputs (16 bit vs 14 bit for the A/D converter)
- Extended temperature range to - 40° C to + 70° C
- Introduction of an USB-C interface (RS232 optional still available)
- Simple extension of bus functionality possible for PROFIBUS, PROFINET and Ethernet-IP

4 Technical data

Feature	Range, characteristics
Supply voltage and Control voltage for digital inputs	12 V DC - 10 % ... 24 V DC + 20 %; residual ripple < 10 % (max. 50 VA power draw)
Solenoid system selection	0.8 A; 1.1 A; 1.3 A; 1.6 A; 2.4 A; 2.7 A and 3.5 A (intermediate values adjustable) For Servo valves: 8 mA up to 550 mA in various increments
Ambiant operating temperature	- 40 °C to + 70 °C
Storage temperature	- 45 °C ... 85 °C
Humidity (relative air humidity)	max. 95 % non condensing
Max. elevation	2,000 m (mamsl)
Class of protection	IP20 when installed in 19" rack system
Connector	In accordance with DIN 41612, 48 pol form F gold plated
EMC	In accordance with the applicable industrial standards (CE - conformity) ¹³
Dimensions front panel / PCB	50,5 x 128,4 mm; 10TE / 3 HE; 100 x 160 mm euro format
Analogue set values inputs	3 inputs with 16 Bit resolution (1 x differential; 2 x single ended; 0 ... +-10 V, 0/4 ... 20 mA)
Analogue feedback U/I	2 inputs with 16 Bit resolution (current and voltage with wide range of adjustability)
Analogue feedback LVDT ¹²	1 or 2 inputs with optional extension board; detailed information on request
Digital inputs	8 inputs (S1.01 ... S1.04, ENABLE, RAMP 0, DIRECTION +, DIRECTION -)
Solenoid current (output)	2 PWM output stages, each for up to 3,5 A (with over-energ. and quick de-energization)
Analogue output	1 output with 12 Bit resolution, 0 ... +-10 V or 4 ... 20 mA (selectable)
Monitor output	1 output with 12 Bit resolution, 0 ... +-10 V
Digital outputs	2 outputs, voltage level 0 V / 24 V, 10 mA (ERROR, COMPARATOR)
Test jacks at front ¹²	Current A and B, sensor 1 (Fb1) set value (S1.06), Monitor and GND
Auxiliary reference voltage	+ - 10 V, max. output 10 mA
Optional digital I/O signals	3 for variable usage, voltage level 24 V or 5 V
Interface 1	USB-C or (optional) RS232, 9-pol SUB-D-connecetor at face plate
Optional interface 2 ¹²	PROFIBUS DP; PROFINET; EtherNet/IP, other bus interfaces on request
Optional sensor interface ¹²	SSI encoder interface RS422. 16 .. 30 data bits, cable length 1 .. 400 m. auto baud rate
Display and keypad ¹²	4-digit 7-segment display, 6 keys, status LED's
PWM frequency	22.2 kHz - independant from dither frequency (customer specific frequencies available)
Cycle times	Closed loop 1 and 2: 0.1 msec

*1: on request

*2: limited to some versions

*3: details on request



5 Comparison technical data „old“ and new advanced version [DAC-44 vs DAC-44(A)]

Feature	DAC-4 „old“	DAC-4(A) „new“
Power supply (range)	24 V nominal	12 – 24 V nominal
Ambient temperature range	0° C ... + 50° C	- 40° C ... + 70° C
Input range set value S1.05	0 ... 10 V	0 ... 10 V; 0 or 4 20 mA
Input range set value S1.06	0 ... 10 V	0 ... 10 V; 0 or 4 20 mA
Input range set value S1.07	0 ... 20 mA	0 ... 10 V; 0 or 4 20 mA
Input range feedback value FB2	0 ... 10 V	0 ... 10 V; 0 or 4 20 mA
Resolution A/D converter for analog signals (set / feedback)	14 bit, theoretical resolution: 0,001 V	16 bit, theoretical resolution: 0.00025 V optional SSI interface
Analog oput	0 ... +-10 V	0 ... +-10 V; 4 20 mA (selectable)
Oscilloscope function for HCSTool	Not available	Available
Interface	RS232, max. 19.200 baud	USB-C; RS232 optional on request
CPU	16 Bit fixed point	32 Bit floating point
PWM frequency	5.55 kHz	22.2 kHz
Cycle time controller 1	250 µsec	100 µsec
Cycle time controller 2	500 µsec	100 µsec

6 Detailed electrical data

Feature	Range, characteristics
Power consumption	4 VA, solenoid not energized 43 VA, one solenoid energized with 3,5 A 83 VA, both solenoids energized with 3,5 A
Solenoid output I _{out} PWM frequency Cycle time current controller	Rectangular voltage, pulse-modulated, with over-energization and quick de-energization Output stages are enabled on the hardware side by the enable signal I _{max} = 4.5 A 22 kHz 45 µs
Analog input Voltage is selected Current is selected over current protection	U _{max} = +28 V U _{min} = -15V Typ. R _{in} = 200 kΩ Differential input S6 Typ. R _{in} = 333 kΩ Input S5, S7 Typ. R _{in} = 5 MΩ Input Fb1, Fb2 Typ. R _{in} = 255 Ω All inputs Typ. > 23 mA
Digital input Supply 10 V Supply 24 V Low level High level	U _{max} = +28 V Typ. I _{in} = 0.8 mA Typ. I _{in} = 2.2 mA U _{in} < 3 V U _{in} > 6 V
Digital Output Error, Comparator Break	Supply 24 V Protected at I _{outmax} typ. 40 mA Typ. U _{out} > 18 V @ I _{out} 2 mA Typ. U _{out} > 15 V @ I _{out} 10 mA, Supply 12 V Protected at I _{outmax} typ. 20 mA Typ. U _{out} > 8 V @ I _{out} 2 mA Typ. U _{out} > 5 V @ I _{out} 10 mA Supply 12/24 V I _{outmax} < 1 A
Analog output Voltage is selected Current is selected	The voltage output is enabled on the hardware side by the signal enable -10 V ... +10V, tol. ±0.020 V 4 mA ... +20 mA, tol. ±0.020 mA
Reference output	+ 10 V, tol. ±0.1 V - 10 V, tol. ±0.1 V I _{outmax} < 10 mA
SSI interface (option)	Rs422 interface level, U _{in} max = +-6V All values can be parameterized using the HCSTool 16 .. 30 data bits 0 .. 2 error bits 1 .. 400 m cable length, the baud rate will be optimized automatically Gray or binary coding

7 Technical data for optional bus interfaces

Bus interface	Range, characteristics	
Supply voltage	Via DAC-4(A) motherboard	
Temperature ranges, EMC, Mounting/housing	Refer to page 2	
PROFIBUS-DP  Connection / Type of connector Status signals Address selection	<ul style="list-style-type: none"> - Certified by PNO - Supports PROFIBUS-DP Slave in accordance with IEC 61158 - Supports PROFIBUS DPV1 	<ul style="list-style-type: none"> - Maximum 244 Byte in-/output data - Supports up to 12 Mbaud (autodetect) - Electrical isolated and opto-decoupled
	RS485, Sub-D 9-pole female	
	LED „Buserror“ (red): DAC-4 error LED is used	
	DIP switch 1- 8, each on/off	
PROFINET  Connection / Type of connector Status signals Future usage	Approved by PNO - Meets the standard IEC 61158 and IEC 61784 - LAN 10/100Base-T(X) - 2 x RJ-45 LAN (Daisy Chain) - Cycling data exchange RT and IRT with PROFINET IO-Controller - Sending and receiving of diagnostic	and process alarms - I&M0...4-data available - Supporting of PROFINET naming (device name) and TCP/IP addressing - Fast Startup functionality supported - Shared Device supported - Media Redundancy Protocol support. - Electrical isolated interface
	In/Out: 2 x RJ45 (integrated switch)	
	Power (green), Error (red), Maint (yellow), Sync (yellow), Status (yellow)	
	DIP switch 1- 3, each on/off	
Ethernet-IP  Connection / Type of connector Status signals Future usage	<ul style="list-style-type: none"> - Electrical isolated and opto-decoupled - supports all speeds - supports 10 and 100 MBit/s auto detect - 2 x RJ-45 LAN - DHCP functionality in preparation (on request) 	<ul style="list-style-type: none"> - input-object instance 100 - output-object instance 101 - Full performance range of Ethernet/IP is supported - Electrical isolated interface
	In/Out: 2 x RJ45 (integrated switch)	
	Status (green)	
	DIP switch 1- 8, each on/off	

8 Block diagram Hardware

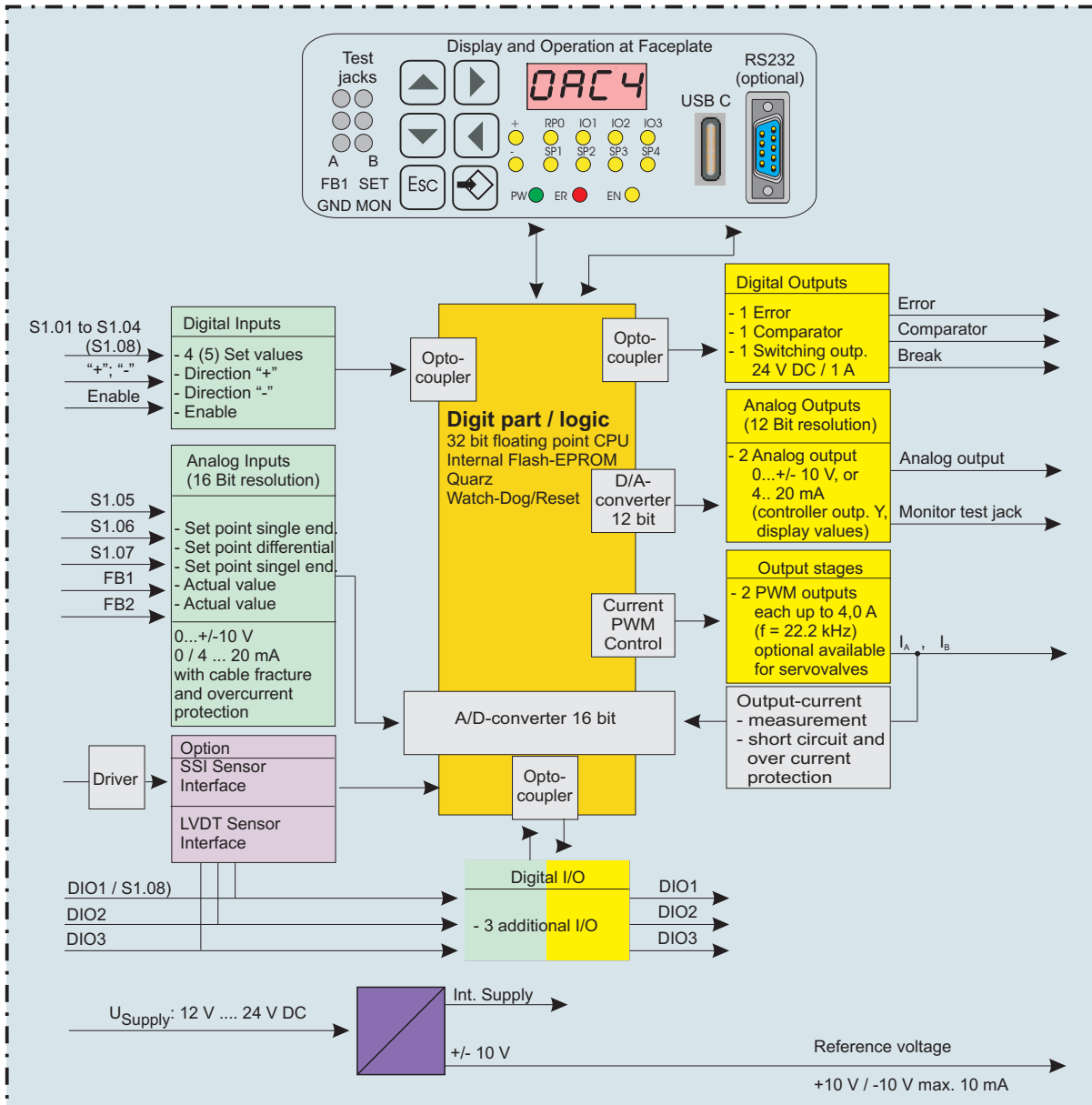

9 Available Operation Modes

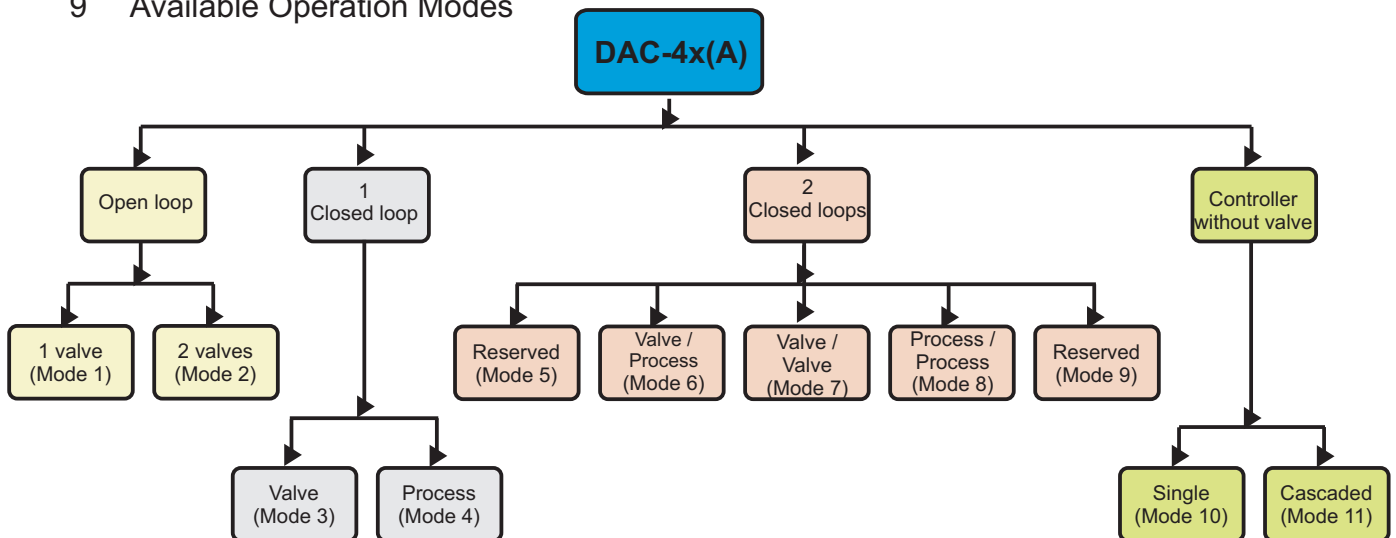

10 Example for Block Diagrams of Software Functions

10.1 Operation Mode 1; one valve with up to two solenoids, open loop

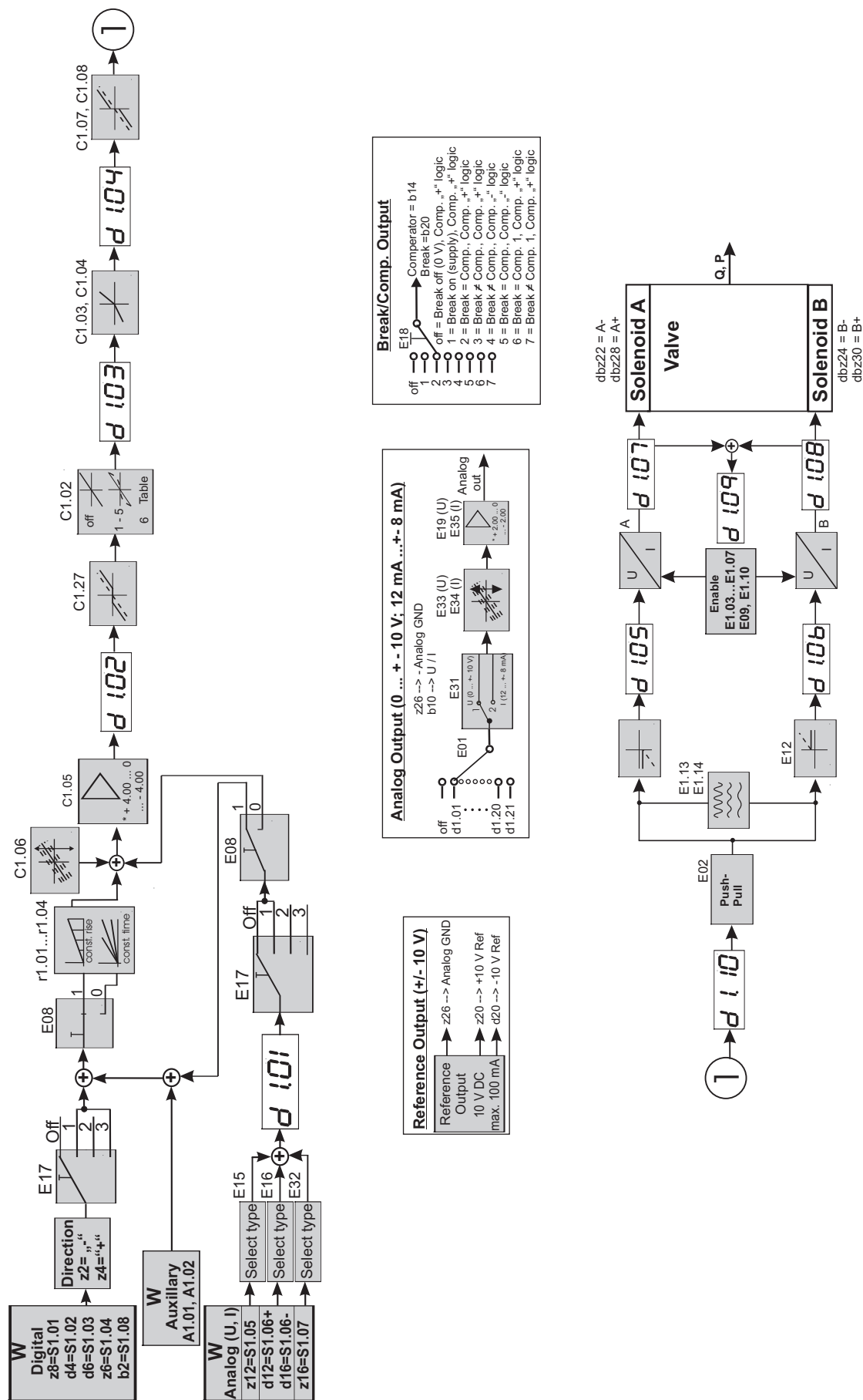

10.2 Operation Mode 2; two valves with one solenoid each, open loop

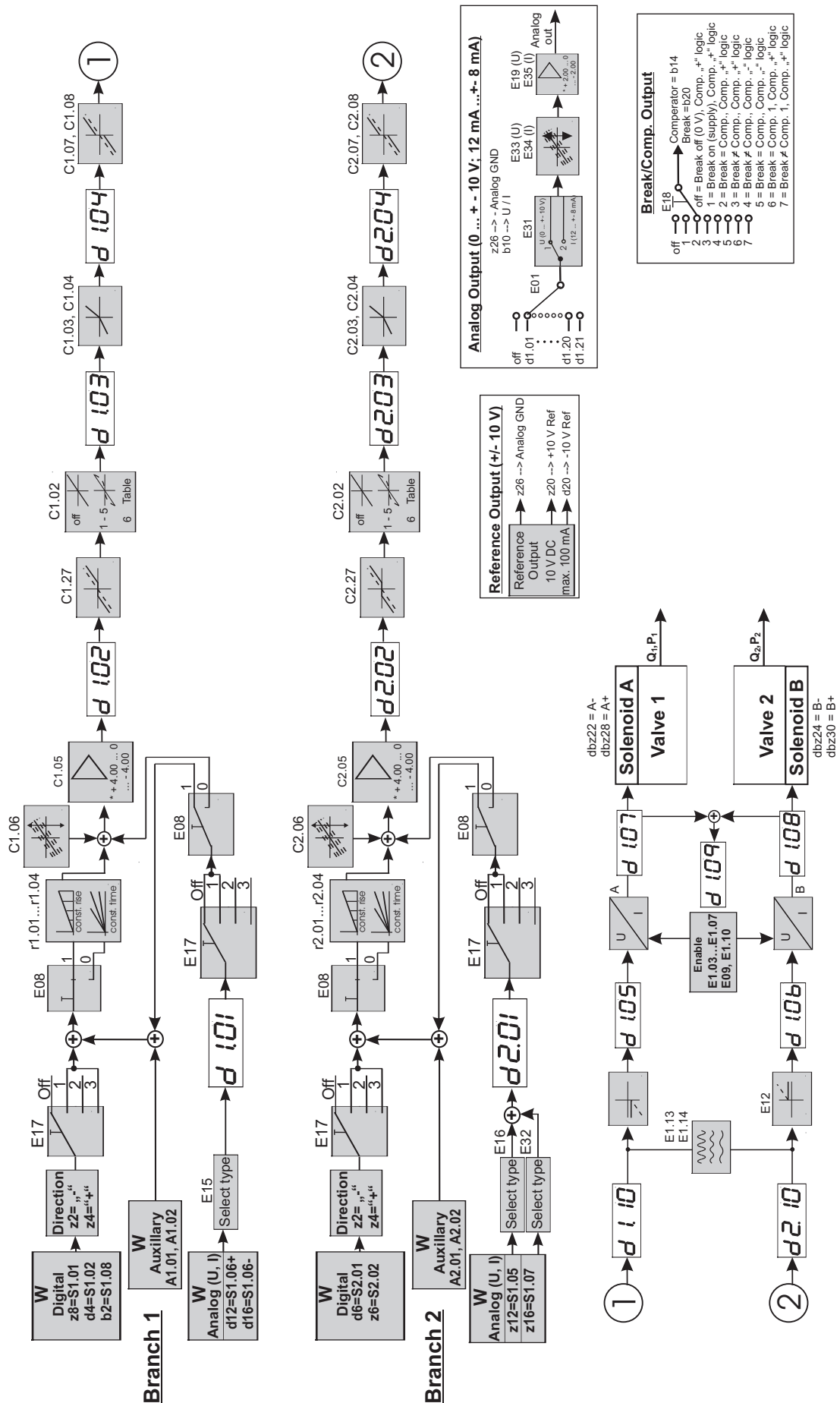

10.3 Operation Mode 3; one valve with spool position feedback

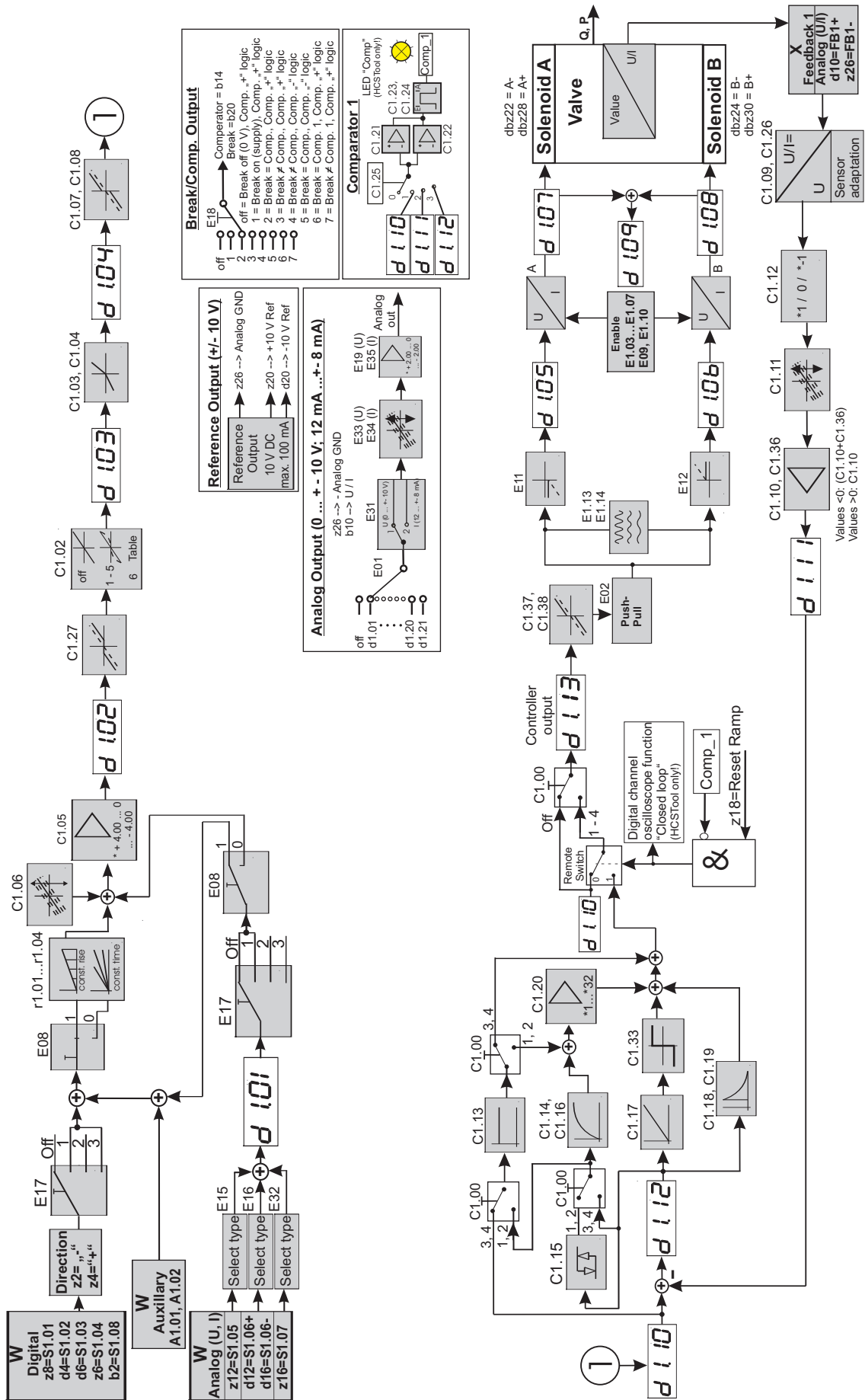

10.4 Operation Mode 4; one valve with process loop control

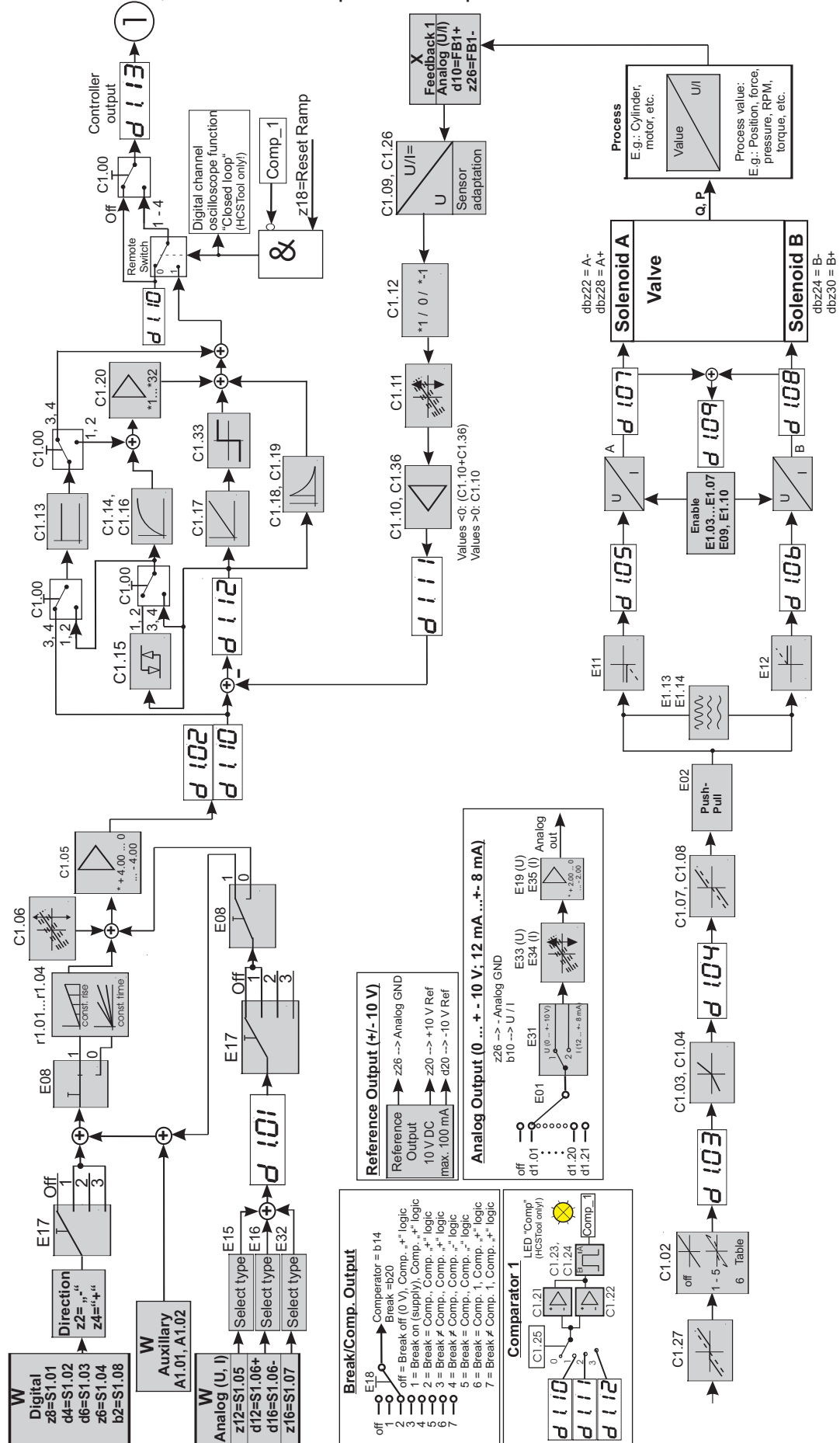

10.5 Operation Mode 6, one valve with spool position and process loop control

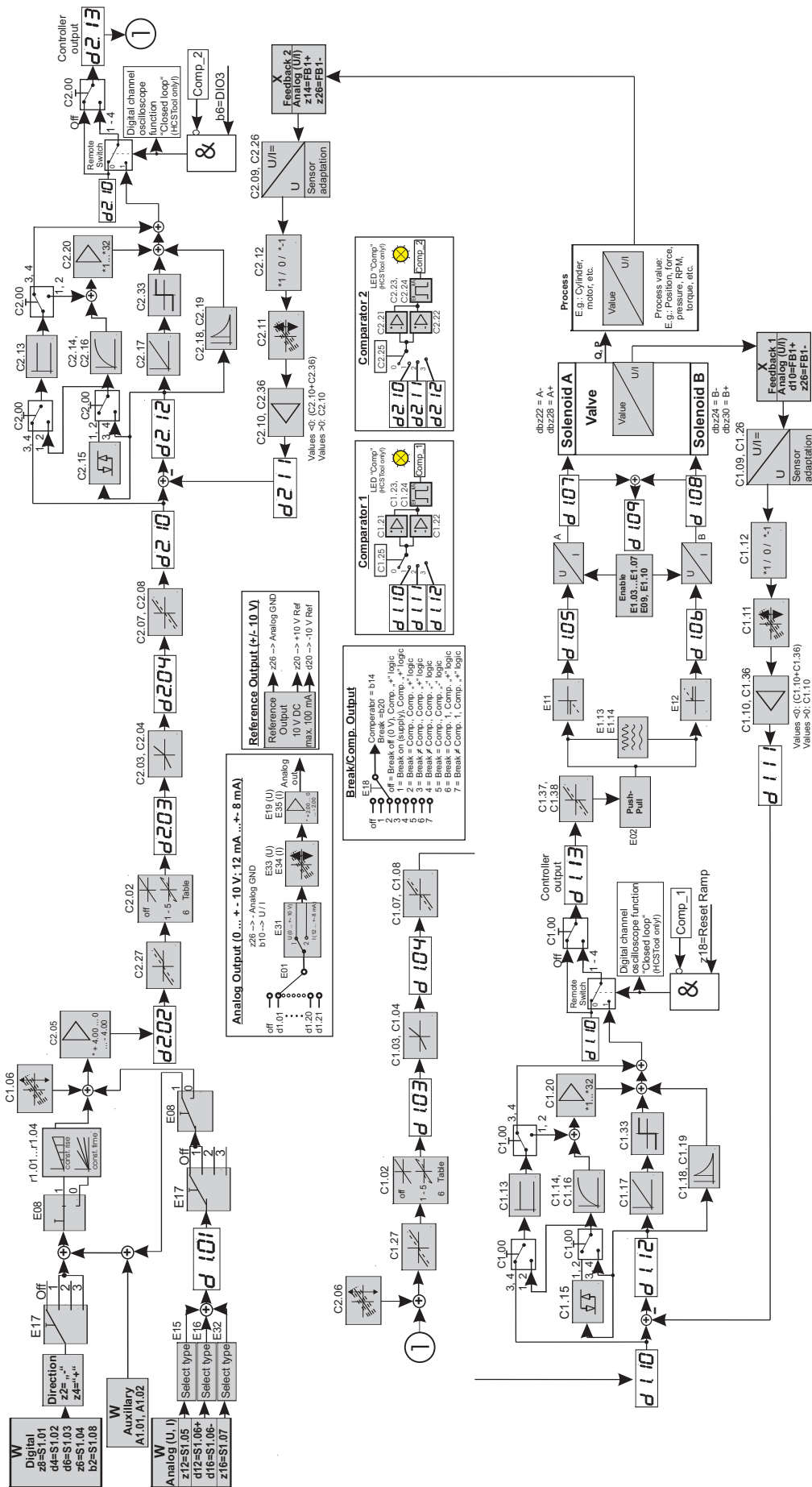

10.6 Operation Mode 10, controller without valve, one closed loop control

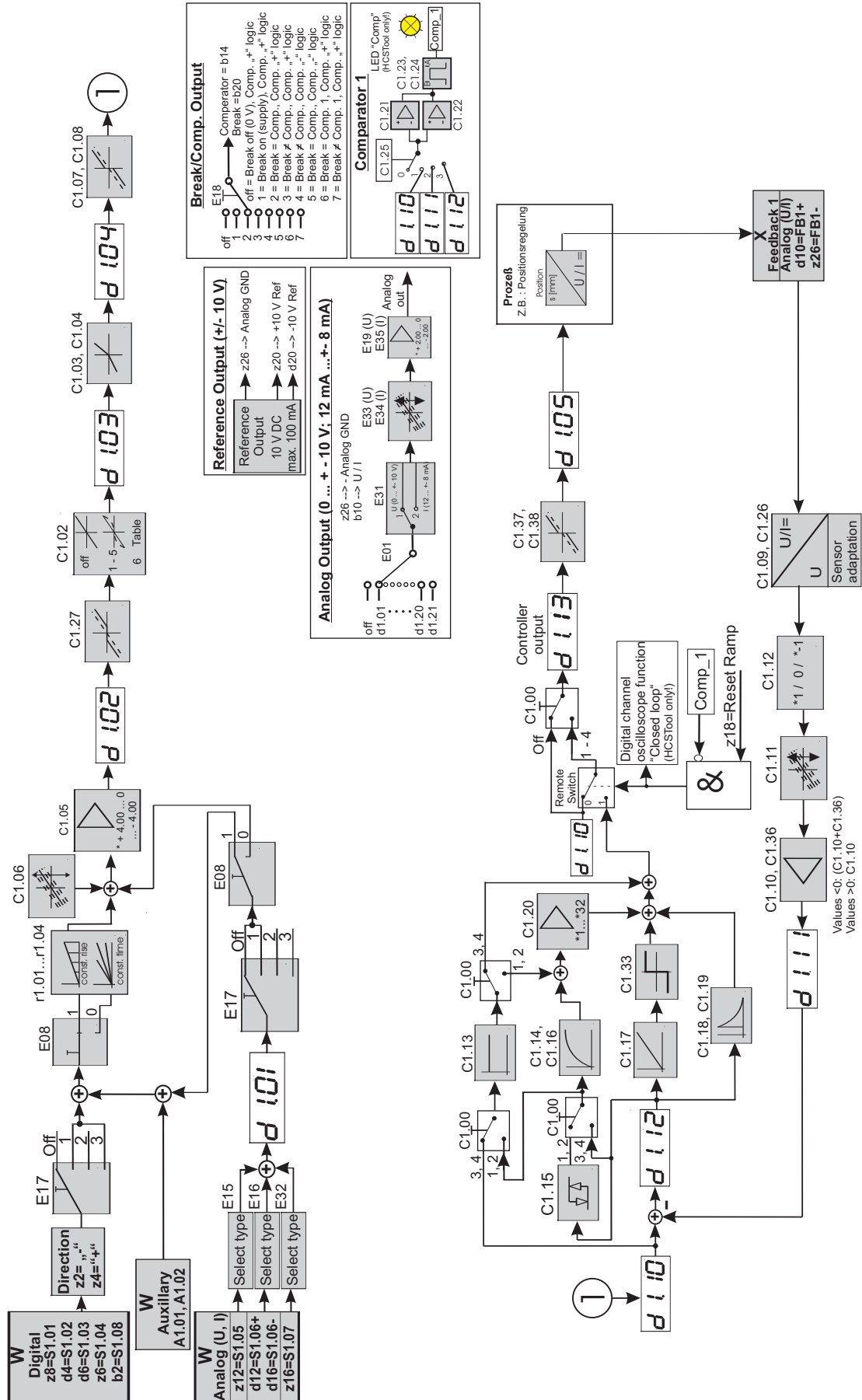

10.7 Operation Mode 11, controller without valve, two cascaded closed loop controls

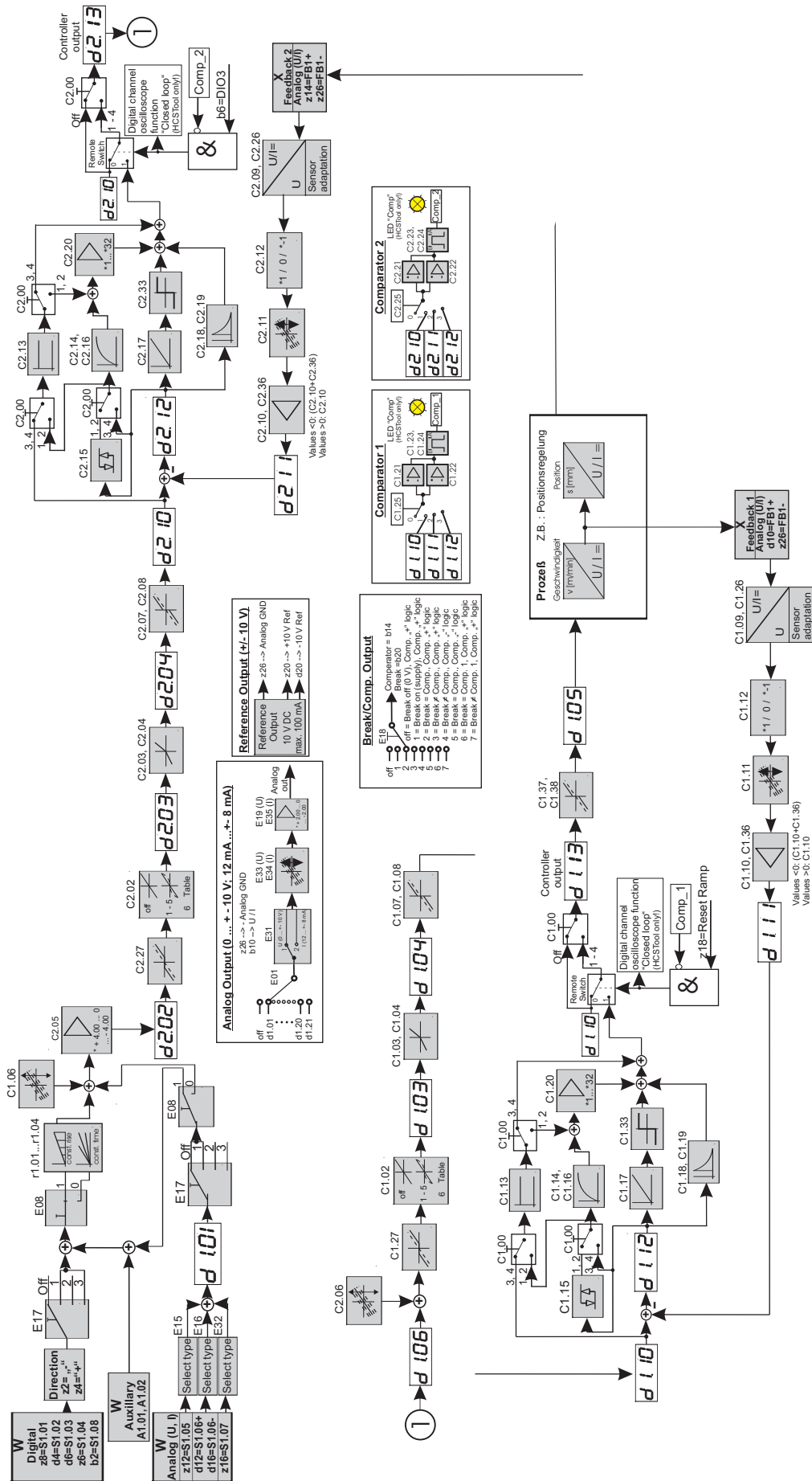

11 Model Code

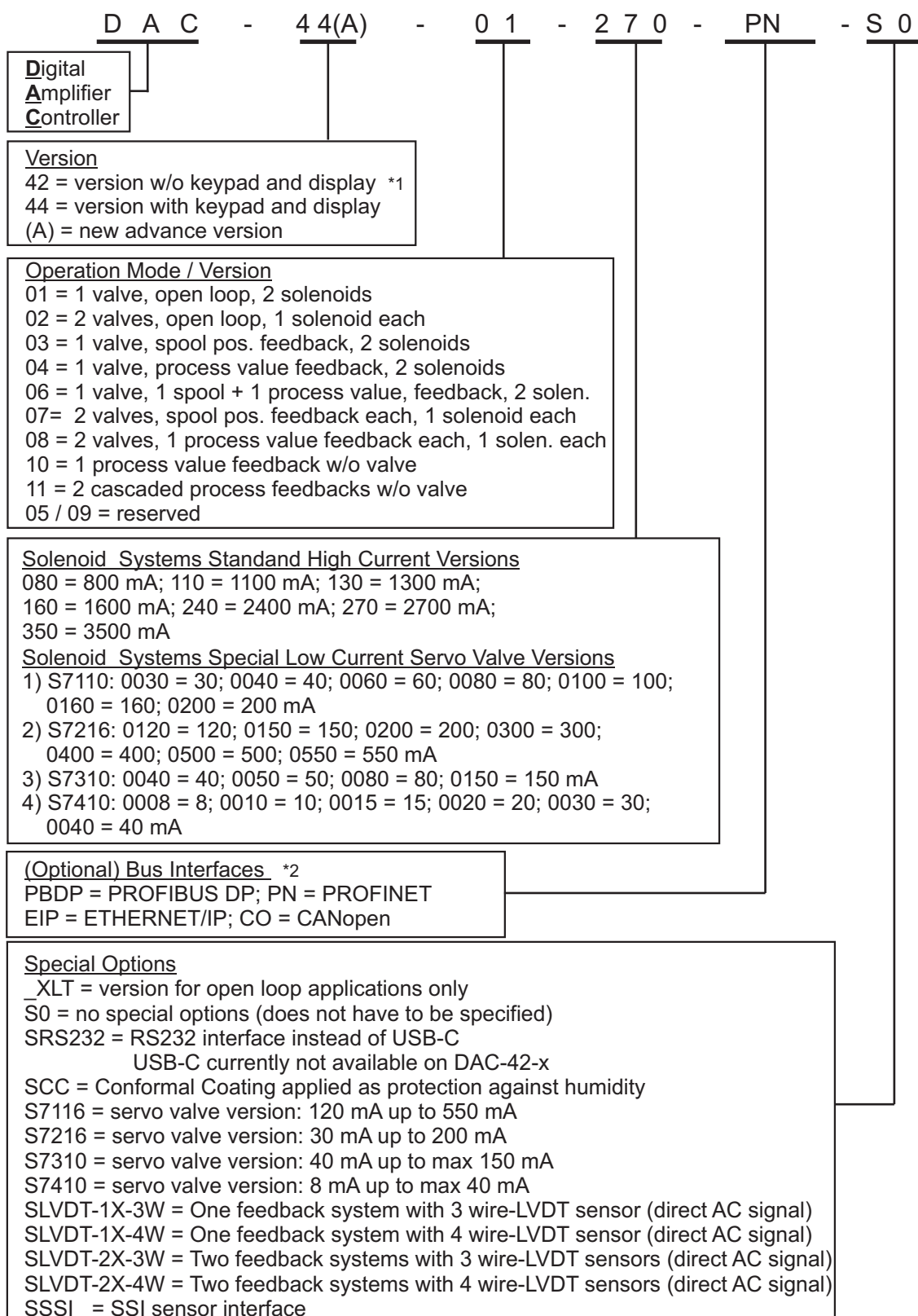

Combinations possible! Other on request

*1: --> only available with RS232 interface!

*2: --> only available without faceplate and keypad and no XLT versions

Model code examples:

Version with display for one valve with
 2.7 A solenoids closed loop operation
 in mode 3. With USB-C interface:

DAC-44(A)-03-270-S0

Version without display for one valve with
 0.8 A solenoids open loop operation in
 mode 1 with RS232 interface and conformal
 coating:





DAC-44(A)-01-080-SRS232-CC-XLT

Version with display for one valve with
 2.7 A solenoids closed loop operation
 in mode 6, one 3-wire LVDT feedback.
 With USB-C interface:

DAC-44(A)-06-270-SLVDT-1X-3W

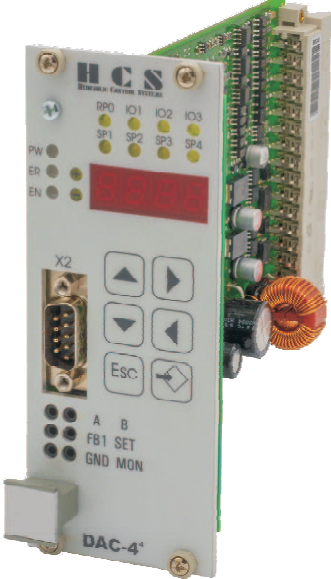
12 Board Versions: General Features and Equipment

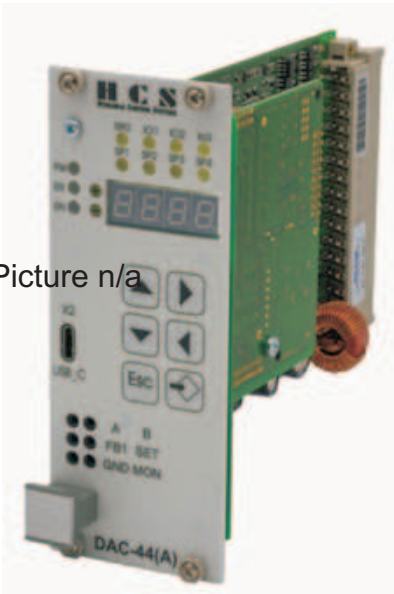
Not to scale!

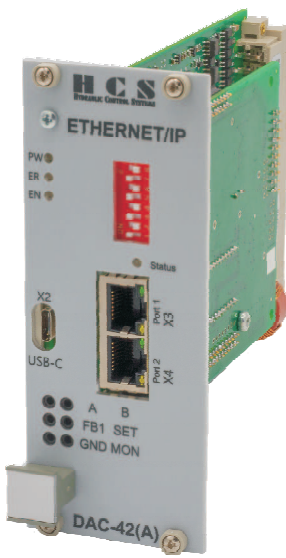
DAC-44(A)-x	DAC-44(A)-x-RS232	DAC-42(A)-XLT-RS232
 <p>The DAC-44(A)-x board features a digital display showing '8888', four status LEDs (RFD, IO1, IO2, IO3, SP1, SP2, SP3, SP4), a USB-C port, and a control panel with four directional buttons and an Esc key. It has four terminal blocks labeled A, B, FB1 SET, and GND MON.</p>	 <p>The DAC-44(A)-x-RS232 board features a red LED display, four status LEDs, a USB-C port, a control panel with four directional buttons and an Esc key, and four terminal blocks labeled A, B, FB1 SET, and GND MON. It includes an X2 RS232 connector.</p>	 <p>The DAC-42(A)-XLT-RS232 board features four status LEDs, a USB-C port, a control panel with four directional buttons and an Esc key, and four terminal blocks labeled A, B, FB1 SET, and GND MON. It includes an X2 RS232 connector and is labeled 'XLT' and 'DAC-42'.</p>
DAC-44(A)-x-LVDT	DAC-42-x-PN	DAC-42-x-EIP
<p>Picture n/a</p>  <p>The DAC-44(A)-x-LVDT board features a digital display showing '8888', four status LEDs, a USB-C port, a control panel with four directional buttons and an Esc key, and four terminal blocks labeled A, B, FB1 SET, and GND MON.</p>	 <p>The DAC-42-x-PN board features four status LEDs, a USB-C port, a control panel with four directional buttons and an Esc key, and four terminal blocks labeled A, B, FB1 SET, and GND MON. It includes an X2 RJ45 connector and is labeled 'PROFI NET' and 'DAC-42(A)'. The status LEDs are labeled Status, Sync, Maint, Error, and Power.</p>	 <p>The DAC-42-x-EIP board features four status LEDs, a USB-C port, a control panel with four directional buttons and an Esc key, and four terminal blocks labeled A, B, FB1 SET, and GND MON. It includes an X2 RJ45 connector and is labeled 'ETHERNET/IP' and 'DAC-42(A)'. The status LEDs are labeled Status, Sync, Maint, Error, and Power. The RJ45 connector is labeled with Port 1, Port 2, Port 3, and Port 4.</p>

13 Our partners and distributors

<https://www.h-c-s-gmbh.de/en/sales-partners>

14 Board Versions: Hardware Features and Functions (Not all features for special versions included!)

	DAC-44(A)-x	DAC-44(A)-x-RS232	DAC-42(A)-x-RS232	DAC-44(A)-x- XLT-x- RS232	DAC-42(A)-x- XLT-x- RS232	DAC-44(A)-x-LVDT	DAC-42(A)-x- PBDP/PN/EIP (PROFINET/PROFIBUS) / EtherNet/IP
Analog SW S1.05	Yes	Yes	Yes	Yes	Yes	Yes	Yes
Analog SW S1.06	Yes	Yes	Yes	Yes	Yes	Yes	Yes
Analog SW S1.07	Yes	Yes	Yes	No	No	Yes	Yes
Analog feedback value Fb1	Yes	Yes	Yes	No	No	Yes *1	Yes
Analog feedback value Fb2	Yes	Yes	Yes	No	No	Yes *1	Yes
Digital Feedback SSI interface	Optional	Optional	Optional	No	No	No	Optional
LVDT actual value 1	No	No	No	No	No	Yes	No
LVDT actual value 2 (only for "-2x")	No	No	No	No	No	Yes	No
Digital Input +	Yes	Yes	Yes	Yes	Yes	Yes	Yes
Digital Input -	Yes	Yes	Yes	Yes	Yes	Yes	Yes
Digital Input S1.01	Yes	Yes	Yes	Yes	Yes	Yes	Yes
Digital Input S1.02	Yes	Yes	Yes	Yes	Yes	Yes	Yes
Digital Input S1.03	Yes	Yes	Yes	Yes	Yes	Yes	Yes
Digital Input S1.04	Yes	Yes	Yes	Yes	Yes	Yes	Yes
Digital Input DIO1 / S1.05	Yes	Yes	Yes	Yes	Yes	No	Yes
Digital Input DIO 2	Yes	Yes	Yes	No	No	No	Yes
Digital Input DIO 3	Yes	Yes	Yes	No	No	No	Yes
Digital Input Reset Ramp	Yes	Yes	Yes	Yes	Yes	Yes	Yes
Digital Input Enable	Yes	Yes	Yes	Yes	Yes	Yes	Yes
Digital Output Error	Yes	Yes	Yes	Yes	Yes	Yes	Yes
Digital Output Comparator	Yes	Yes	Yes	No	No	Yes	Yes
Digital Output Break (24 V max. 1 A)	Yes	Yes	Yes	No	No	Yes	Yes
Test Jacks	Yes	Yes	Yes	No	No	Yes	Yes
Piggy-Back possible for options	Yes	Yes	Yes	Yes	Yes	Yes	Yes
USB-C Interface	Yes	No	No	No	No	Yes	Yes
RS232 Interface	No	Yes	Yes	Yes	Yes	No	No
PROFNET Interface	No	No	No	No	No	No	Yes *2
PROFIBUS Interface	No	No	No	No	No	No	Yes *2
EtherNet/IP Interface	No	No	No	No	No	No	Yes *2
Ref. Output + - 10 V	Yes	Yes	Yes	Yes	Yes	Yes	Yes
Analog Output (0...+- 10 V; 4...20 mA)	Yes	Yes	Yes	No	No	Yes	Yes
Monitor Output (0...+- 10 V)	Yes	Yes	Yes	No	No	Yes	Yes
Operation by means of PC	Yes	Yes	Yes	Yes	Yes	Yes	Yes
Aluminium faceplate only (10 TE)	No	No	Yes	No	Yes	No	Yes
7-Segment-Display / Keypad (10 TE)	Yes	Yes	No	Yes	No	Yes	No









*1: Depending on LVDT version

*2: Depending on selected bus interface version

15 Accessories and Options

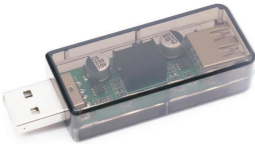
Name	Description
HCSTool	Software for parameterization, operation, monitoring, storage and documentation of adjustments. With 4-channel oscilloscope function. In E / F/ DE on CD. Donwload from internet: http://www.h-c-s-gmbh.de/download/
USB-RS232-DS9F-2,5m	Interface cable for communication between PC and DAC-4x(A) for RS232 interface. with USB to RS232 adaptor. Sub-D 9-pole connector fem. w. approx. 2,5 m cable
USB-A-USB-C-2m	Interface cable for communication between PC and DAC-4x(A) for USB-C interface. 1 x USB-A connector (PC side), 1 x USB-C connector (DAC side) approx. 2 m cable
Galvanically Isolated USB Adaptor	Adapter for communication between PC and DAC-4x(A) for USB interface with galvanic isolation. Isolation voltage 1,500 V RMS. USB Type-A male to USB Type-A female. Bus-powered, no external supply required.
USB-C-USB-C-2m	Interface cable for communication between PC and DAC-4x(A) for USB-C interface. 2 x USB-C connector (PC and DAC side), approx. 2 m cable
CU/DAC-4	Commissioning unit for DAC-4x(A). For adaptation of 1 x DAC-4x(A) board. For commissioning, serviceing, testing and trouble shooting etc. at machines, systems, for laboratories and for training. In metal case with handles including power supply
SKT48F	Card holder for mounting of single board; with connector form F, 48-pole
BP48F	Back-Plane for easy and quick wiring; with connector female form F 48-pole For usage in 19"-Rack systems
MR/BP48F	Modul-Rack completely mounted with Back-Plane

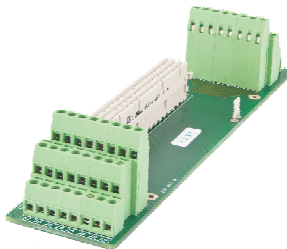
Not to scale!

HCSTool	Interface Cable „USB-A-USB-C“	Interface Cable „USB-C-USB-C“	Interface Cable „USB-RS232!“
			
	Galvanically Isolated USB Adaptor		
			
Commissioning Unit	Card Holder	Back-Plane	Module-Rack
			

EC Declaration of Conformity in accordance with EMC Directive 2014/30/EU

HCS Hydraulic Control Systems GmbH
Neuffener Str. 29
D-72636 Frickenhausen

hereby declares that the product described as follows complies in terms of its design, as well as in the version placed in the stream of commerce by us, with the relevant requirements of the directive. This declaration is void in the event of any change to the product without our written agreement.

Product:	Digital Amplifier and Controller
Intended use:	Automation systems (industrial applications)
Model:	DAC-4x(A)
Rated voltage:	24 V DC; SELV
Rated power:	max. 100 W
Protection class:	III
Protection degree:	IP00
Relevant EU Directive:	EMC Directive 2014/30/EU
Applicable EU Standards:	
Emissions:	EN 61000-6-3:2007 + A1:2011 EN 61000-6-4:2007 + A1:2011
Immunity:	EN 61000-6-2: 2005
Date/manufacturer's signature	
01.01.2024	
Details of signatory:	Dipl.-Ing. (FH) Peter Deuschle (General Manager)

Hydraulic Control Systems GmbH Geschäftsführer / General Manager: Dipl.-Ing. (FH) Peter Deuschle + Dipl.-Ing. (FH) Volker Bremauer
 Sitz / Head Quarter: D-72636 Frickenhausen Amstgericht / Register Court: AG Stuttgart HRB 224899
