

**THE ART OF  
CONTROL**

Neuffener Strasse 29  
D-72636 Frickenhausen  
Tel: (+49) 7025 - 911 007  
Fax: (+49) 7025 - 911 008  
Email: info@h-c-s-gmbh.de  
www.h-c-s-gmbh.de



## EXTERNAL KEYPAD AND DISPLAY UNIT

# EKB-04

### FOR DAC, DMA AND OTHER

- ◆ Used for Parameterisation of digital amplifiers and controller board and modules series DAC-4 and DMA-2 (other on request)
- ◆ Handheld keypad and display unit
- ◆ Online-change of single parameters or Up-/Download of parameter sets
- ◆ Compact design
- ◆ LCD with two lines
- ◆ Copy function to transfer parameters
- ◆ Accumulator for flexible and independent use
- ◆ Automatic standby mode
- ◆ No PC required for parameter changes
- ◆ Connection to PC possible via USB port
- ◆ Simple operation
- ◆ No additional software required



## 1 Introduction

The keypad and display units EKB-04 feature leading edge technology. This electronic device meets the industrial standards for EMC. This ensures a high interference security and low interference emission.

The performance characteristics are possible through the use of the most current microprocessor technology. System features are essentially determined by the software and provide reserve capacity for further developments and adaptations

## 2 Features

- Handheld keypad and display unit
- Online-change of single parameters or Up-/Download of complete parameter sets
- Compact design
- LCD with two lines
- Copy function to transfer parameters from one amplifier to another amplifier of the same type and software version
- Accumulator for flexible and independent usage
- Automatic standby mode to save accumulator time
- No PC required for parameter changes in field applications
- Connection to PC possible via USB port
- Simple operation
- No additional software required

## 3 General applications

EKB-04 is used for Parameterisation of digital amplifiers and controller board and modules series:

- DAC-4
- DMA-2
- Spezial boards and customer specific applications (on request)

## 4 Technical data

Feature	Range, description
Power supply	24 V DC ca. 100 mA (via power supply from mains); 9 V (accumulator supply) Attention: only use the included or power supply or accumulator! Do <b>not</b> use 9 V batteries!
Ambient temperature	0 °C ... 50 °C
Storage temperature	- 20 °C ... 60 °C
Display	Monochrome; two lines with 8 characters each with back light Contrast and back light adjustable
Keypad	On/Off, Function key, Enter, ESC, Up, Down, Left, Right
<b>Connection</b>	
Power supply	To power supply: Female jack size 2,1 x 5,5 x 12 To accumulator: E-Block connection in accumulator tray
RS232-interface (RJ45)	For connection with amplifier/controller board or to the PC
USB-interface	USB B for connection with PC (Communication via <b>HCSTool</b> *1)
<b>EMC</b>	
EMC	EN 55011 Class B, EN 61000-6-1
<b>Housing</b>	
Dimensions (L x B x H) / Weight	165 x 90 x 30 mm / 245 g
Material	ABS (Acrylnitril-Butadien-Styrol); grey (RAL 7038) and. blue (RAL 5015)
Accumulator tray	On back side of unit, to be opened with out tool; form: E-Block
<b>Charger and power supply</b>	
Make / version	Deutronic / ESC15-24
Input voltage	100 – 240 VAC (range: 90 – 264 VAC), 47 – 67 Hz
Power consumption	0,5 A max
Inrush current during power on	30 A max. / 264 VAC
Output voltage	24 VDC
Current limitation	Hick-Up
Voltage deviation (load change).	± 2 %
Voltage deviation (input change)	± 1 %
Residual ripple	1 % peak/peak
Power cut out protection	10 ms typical / 115 VAC
Ambient temperature	0° C + 40° C
Storage temperature	- 20° C - + 85° C
Short circuit protection	Continuous (automatic re-start)
Isolation voltage	Input / Output 3 kV, routine tested in accordance with EN 60950
EMC	EN 55011 class B, EN 61000-6-1
Connector input	Euro connector
Connector output	Ca. 1,8 m 2-wire cable with male connector 2,1 x 5,5 x 12 mm
Dimensions (L x B x H) / weight	72 x 52 x 35 mm / 130 g

## 4 Technical data (continued)

<b>Accumulator</b>	
Male / version	Panasonic / NiMH Pro plus; 9 V/170 mAh
Operation time	Ca. 2 Std
Charge current	Ca. 20 mA; the accumulator is only charged when the unit is switched on
Time until fully charged	Ca. max. 8 Std.
<b>Connection cable RS232/RJ45</b>	
Make	HCS GmbH
Version	DMA-RS232-DS9F_RJ45_2m
HCS Article-no.	1 860 002 00
Connector side 1	RJ45 8-pole; connection between to DMA / EKB-04
Connector side 2	RJ45 8-pole; connection between to DMA / EKB-04
Connector 3 / adapter	From RJ45 8-pole to Sub-D 9-pole female (RS232) Connection between DMA / EKB and PC (adapter side at PC) or connection between DAC-4 and EKB (adapter side at DAC-4)
Cable length	Ca. 2 m
Weight	Ca. ca. 70 g (with adapter)
<b>USB connection cable</b>	
Make	Farnell (article-no. 8706760)
Version	Pro Signal USB2-102X_USB 2.0 A-B 2 m clear
HCS Article-no.	1 860 005 00
Connector 1	USB A Plug; connection to PC
Connector 2	USB B Plug; connection to EKB
Cable length	Ca. 2 m
Weight	Ca. 60 g

\*1: **HCSTool**: Software for parameterisation for WINDOWS OS. Please order separately.

## 5 Connection / communication possibilities

Connection HCS device PC (with HCSTool software)  
via RS232 -interface with RJ45 adapter (e.g. DMA)



Connection HCS device EKB via RS232 interface (e.g. DMA)



## 9 Ordering code

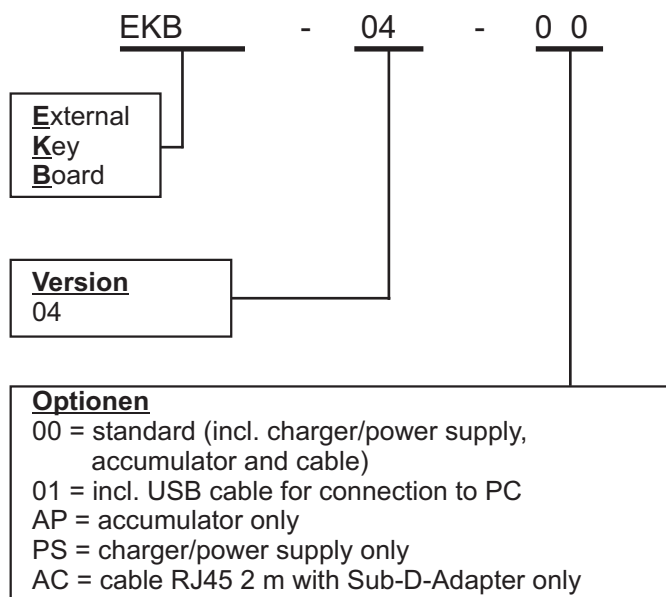

## 10 Our partners and distributors

**Europe****NORWAY, ALL NORDIC COUNTRIES****Servi Hydranor AS**

Rasmus Solbergs vei 1  
N-1400 Ski  
Norway  
Tel.: (+47) 64 - 979 797  
Fax: (+47) 64 - 979 899  
Borre.Kleven@servi.no  
www.servi.no

**SWEDEN I (South-West)****PMC Hydraulics AB**

Askims Verkstadsväg 15  
Box 1013  
SE-43621 Askim  
Sweden  
Tel.: (+46) 31 - 28 98 40  
Fax: (+46) 31 - 28 64 01  
Per-Anders.Kallden@pmchydraulics.se  
www.pmchydraulics.se

**SWEDEN II (North-East)****Norrlands Hydraulik**

Stenhuggargatan 4  
SE-913 35 Holmsund  
Sweden  
Tel.: (+46) 70 - 646 57 57  
kurt.w@norrhyd.se  
www.norrlandshydraulik.se

**SWITZERLAND****GRIBI Hydraulics AG**

Lättenstr. 33  
CH-8952 Schlieren  
Switzerland  
Tel.: (+41) 1 733 - 40 50  
Fax: (+41) 1 730 - 58 05  
info@gribi-hydraulics.ch  
www.gribi-hydraulics.ch

**GREAT BRITAIN****Voith Turbo Ltd.**

6 Beddington Farm Road  
Croydon, Surrey  
England CRO 4XB  
Tel: (+44)208 667 0333  
Fax: (+44) 208 667 0403  
nick.moody@voith.com  
www.uk.voithturbo.com

**FRANCE****SEFYDRO**

Pôle République 1  
23, Rue des Entrepreneurs  
BP 1086  
F-86060 POITIERS  
Tel. : (+33) 549 607 016  
Fax. : (+33) 549 602 480  
bureau.etudes@sefydro.fr  
www.sefydro.fr

**ITALY****BIMAL TESTING MACHINES S.R.L.**

Automation & Software Department  
Zona Industriale - Via A. Monni, 18  
I-06135 Ponte Vallecceppi (Perugia)  
Italy  
Tel.: (+39) 075 - 592 171  
Fax: (+39) 075 - 592 1740  
automazioni@bimal.com  
a.paolucci@bimal.com  
www.bimal.com

**SPAIN I****HRE HIDRAULIC S.L.**

C / Ibaitearte, 21  
E-20870 Elgoibar  
Spain  
Tel.: (+34) 943 - 742 130  
Fax: (+34) 943 - 742 708  
hre-hidraulic@hre.es  
www.hre.es

**SPAIN II****GLUAL HIDRAULICA, S.A.**

Landeta Hiribidea, 11  
E-20730 Azpeitia (Gipuzkoa)  
Spain  
Tel.: (+34) 943 157 015  
Fax: (+34) 943 157 404  
j.valverde@glual.es  
www.glual.com

## 10 Our partners and distributors

**ROW I****USA I****SERVI FLUID POWER INC.**

22240 Merchants Way | Suite 100  
Katy, TX 77449, USA  
Tel.: (+1) 281 - 347 8080  
info@servi-inc.com  
www.servi-inc.com

**USA II****NC SERVO TECHNOLOGY INC.**

38422 Webb Drive  
Westland, MI 48185-1974, USA  
Tel.: 1-800 327 - 3786  
Tel.: (001) 734 - 326 6666  
Fax: (001) 734 - 326 6669  
sales@ncservo.com  
www.ncservo.com

**USA III****Hawe Hydraulik - East**

9009-K Perimeter Woods Drive  
Charlotte, NC 28216, USA  
Tel: (+1) 704 509 1599  
Fax: (+1) 704 509 6302  
sales@hawehydraulics.com  
www.hawe.com

**USA IV****Hawe Hydraulik - Central**

10920 W. Sam Houston Pkwy N.  
Suite 700  
Houston, TX 77064  
Tel: (+1) 713 - 300 3260  
Fax: (+1) 281 - 970 6692  
sales@hawehydraulics.com  
Also:  
Cell: (+1) 832 - 797 4608  
m.paxton@hawehydraulics.com  
www.hawe.com

**USA V****Hawe Hydraulik - West**

912990 S.E. HWY 212  
Clackamas, OR 97015, USA  
Tel: (+1) 503 222 3295  
Fax: (+1) 503 225 5976  
sales@hawehydraulics.com  
www.hawe.com

**CANADA and USA VI****HYDRA-FAB  
FLUID POWER INC.**

3585 Laird Road Unit 5  
Mississauga, Ontario L5L 5Z8  
Canada  
Tel.: (+1) 905 - 569 1819  
Fax: (+1) 905 - 569 7801  
rgores@hydrafab.com  
www.hydrafab.com

**BRASIL, SOUTH AMERICA****Voith Turbo Ltda**

Av. Fernando Stecca, 575  
Alto da Boa Vista  
BR - 18087 - 450 Sorocaba / SP  
Tel.: (+55) 15 228 1114  
Fax: (+55) 15 228 1115  
friedrich.guther@voith.com  
www.hl-hydraulic.com



## 10 Our partners and distributors

**ROW II****ASIA****KC Kim Consulting GmbH**

Support in German, English,  
Chinese and Korean  
Industrial Engineering Im- und Export  
Lilienthalstr. 3  
D-30916 Isernhagen  
Tel: +49 (0)511-898809-17  
Fax: +49 (0)511-898809-29  
c.kim@kc-co.com  
info@kc-co.com  
www.kc-co.com

**AUSTRALIA I (Brisbane)****Hydraulic Specialists  
Australia Pty Ltd**

21 Production Street, Wacol  
Queensland,  
Australia, 4076  
Tel: +61 (07) 3879 4400  
Fax: +61 (07) 3879 4333  
brisbane@hsaus.com.au  
lharley@qldhsaus.com.au  
www.hsaus.com.au

**AUSTRALIA II (Melbourne)****Hydraulic Specialists  
Australia Pty Ltd**

9 National Drive , Hallam  
Victoria  
Australia, 3803  
Tel: +61 (03) 9796 5433  
Fax: +61 (03) 9796 4955  
melbourne@hsaus.com.au  
lharley@qldhsaus.com.au  
www.hsaus.com.au

**INDIA****Greentech Engineers Australia**

Mr. Vish Karegowda  
Mount Waverley, Victoria  
Australia, 3149  
Tel : +61(03) 9803 5941  
contact@greentechea.com.au  
www.greentechea.com.au  
Skype : grnhorizon